

PRODUCT INFORMATION

PROCESS ANALYSIS

UVAS PLUS SC

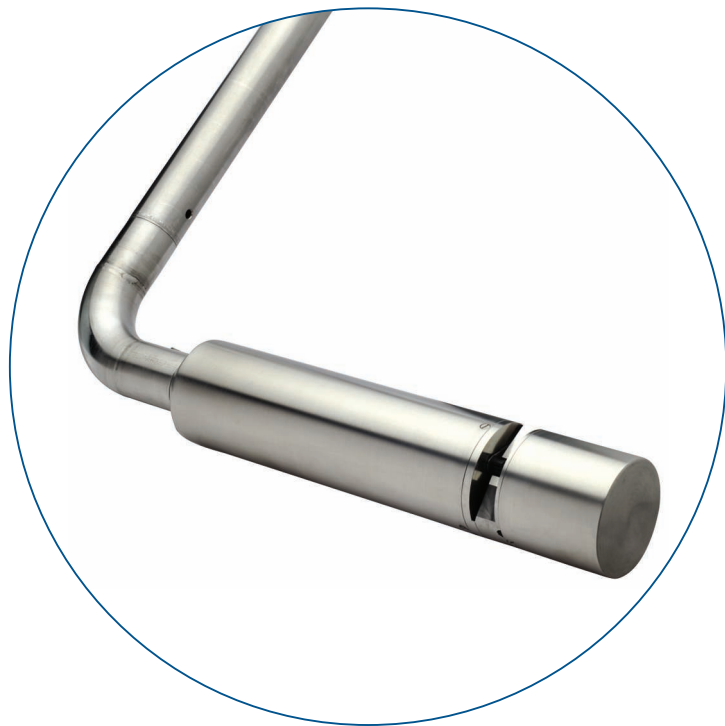

Continuous measurement of organic load: UVAS plus sc

- **No sampling or sample conditioning**
- **Instant measured values**
- **No reagents**
- **Self-cleaning probe**

Reagent-free measurement of organic load

The UVAS plus sc process probe measures the spectral absorption coefficient of a fluid at 254 nm. The SAC 254 is a measure of the organic content of the fluid. The probe is simply submerged in the fluid, without taking samples. No reagents have to be added and the measured values are immediately available.

Fast results, simple handling, low costs

The UVAS plus sc probe is mounted in the fluid and supplies results within seconds. Handling and maintenance are very simple, thanks to automatic cleaning with a wiping system. The reagent-free measurement method yields reliable measured values for extremely low operating costs.



LANGE 



Installed immersion probe

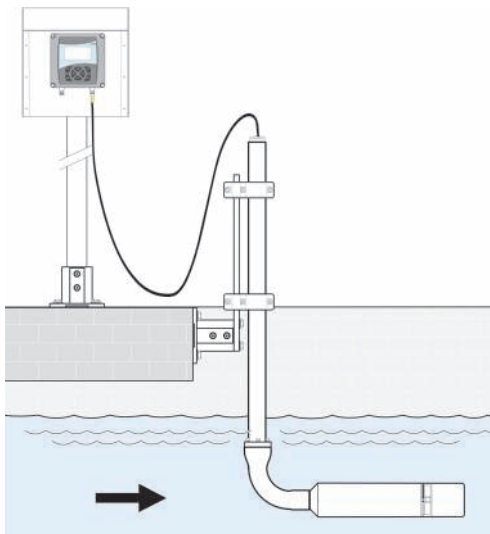

UVAS plus sc in the flow-through unit

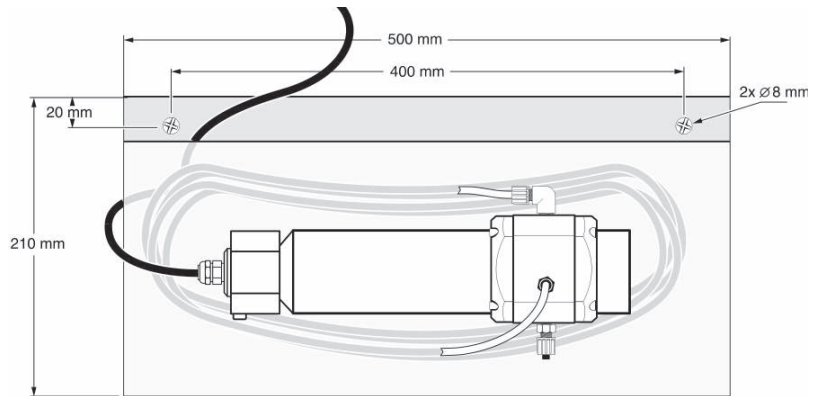

Technical data

Measuring method	UV absorption measurement (2-beam method), reagent-free
Measurement method	SAC 254 to DIN 38404 C3
Measuring range	0.01-60 m ⁻¹ (50 mm), 0.1-600 m ⁻¹ (5 mm), 0-500 m ⁻¹ (2 mm), 2-3,000 m ⁻¹ (1 mm), calibratable for the sum parameters COD and TOC
Path length	1, 2, 5 and 50 mm
Compensation	550 nm
Measurement interval	>1 min
Cable length	10 m
Pressure resistance of probe	Max. 0,5 bar
Ambient temperature	+2°C to +40°C
Cleaning	Automatic wiper cleaning
Material	Probe housing made of stainless steel 1.4571
Weight	Approx. 3.6 kg
Inspection interval	6 months
Maintenance	1 h/month, typical
Sample flow	At least 0.5 l/h sample in the flow-through unit
Sample connector	Flexible tube (ID 4 mm/ OD 6 mm) in the flow-through unit
Dimensions of the flow-through unit	210 mm x 500 mm x 170 mm (H x L x D)
Dimensions	Approx. 70 mm x 333 mm (Dia. x L)
Display unit	SC 100 controller (model LXV401) or SC 1000 controller (model LXV400 and LXV402)

Ordering information

DESCRIPTION	ART. NO.
UVAS plus sc	
- 1 mm	LXV418.99.10001
- 2 mm	LXV418.99.20001
- 5 mm	LXV418.99.50001
- 50 mm	LXV418.99.90001
ACCESSORIES	
Basin rim mounting	LZX414.00.10000
Flow-through unit 2 mm SC probes	LZX869
Flow-through unit 5 mm SC probes	LZX867
Flow-through unit 50 mm SC probes	LZX868
SPARE PARTS	
Wiper profiles	
- 1 mm (5/pkg)	LZX148
- 2 mm (5/pkg)	LZX012
- 5 mm (5/pkg)	LZX117
- 50 mm (10/pkg)	LZX119

HACH LANGE LTD
Pacific Way
Salford
GB-Manchester, M50 1DL
Tel. +44 (0)161 872 1487
Fax +44 (0)161 848 73 24
info@hach-lange.co.uk
www.hach-lange.co.uk



Phone: (0161) 872 14 87

HACH LANGE Services



Contact us to place an order, request information or receive technical support.



Support on-site by expert sales team.

