

CLF10 sc and CLT10 sc Free and Total Reagentless Chlorine Analyzers

**EPA
COMPLIANT**

Free/Total Chlorine

Overview

With over 60 years of industry leadership, Hach provides you with the best products and application knowledge for chlorine monitoring. Our portfolio includes the CLF10 sc and CLT10 sc reagentless chlorine analyzers and the market-leading CL17 chlorine analyzer, as well as Hach laboratory colorimeters, spectrophotometers and chemistries. Let Hach guide you to the best disinfection solution.

Features and Benefits

Exclusive Self Diagnostics

The CLF10 sc and CLT10 sc analyzers leverage Hach's exclusive self diagnostics to alert users whether the process has changed or the instrument needs servicing. Diagnostic features include the Cal Watch algorithm for warning of pH and chlorine calibration deviation and a non-contacting flow sensor for notification of insufficient sample flow.

No Reagent Replacement, No Waste Stream

Chlorine measurement with an amperometric analyzer, such as the CLF10 sc or CLT10 sc, does not require reagents, eliminating the need for routine reagent replacement and waste stream management.

Real-Time Process Control

The CLF10 sc and CLT10 sc analyzers allow for real-time control of disinfection processes by providing continuous readings that indicate when treatment conditions have changed.

Compatible with Hach's "Plug and Play" Digital Controllers

The CLF10 sc and CLT10 sc analyzers can be used with any Hach sc digital controller. Whether you're measuring turbidity or chlorine, you only need to learn one controller for all your water analysis measurement points. Hach sc controllers, have no complicated wiring or setup procedures. Just plug in any Hach digital sensor and it's ready to use without software configuration.

EPA Compliant According to Method 334.0

In accordance with EPA Method 334.0, the CLF10 sc and CLT10 sc analyzers can be used for reporting chlorine residual measurements. Additionally, Hach has created a suite of laboratory products and methods to help with startup and quality control procedures required in Method 334.0. (See page 4 for a partial listing of accessories.)



From the leaders in disinfection monitoring, the right instrument for reagentless chlorine analysis.

Applications

The CLF10 sc and CLT10 sc analyzers are best suited for static applications where sample pH, flow, temperature and chlorine concentration are stable. Hach recommends these analyzers for trending in dynamic applications where these parameters vary. Be sure to consult a Hach application expert to match the best instrument to your application.

Drinking Water— The CLF10 sc and CLT10 sc analyzers can be used in applications where waste stream management is a challenge, such as residual chlorine monitoring in ground water systems and the distribution system. Additionally, these analyzers can be used for process control in at-the-plant applications where real-time continuous results are beneficial.

Power Plants— The CLF10 sc and CLT10 sc analyzers can be used for the control of disinfection processes in boiler operations and cooling systems.

General Industrial— The CLF10 sc and CLT10 sc analyzers can be used to monitor chlorine residual to prevent biological build-up in applications serving various industrial processes (feed water), HVAC operations (cooling water), or in food and beverage applications.

Wastewater— The total chlorine analyzer, CLT10 sc, can be used to monitor chlorine residual and control chlorination processes in wastewater treatment. For this application, Hach recommends using the acidification/cleaning kit to ensure continuous operation.

DW

WW

PW

IW

DW = drinking water WW = wastewater municipal PW = pure water / power
IW = industrial water E = environmental C = collections FB = food and beverage



Be Right™

Specifications*

Chlorine Sensor

Measurement Range

0 to 10 ppm

Lower Limit of Detection (LOD)

30 ppb (0.03 ppm) or lower

Limit of Quantitation (LOQ)

90 ppb (0.09 ppm) or lower

Resolution

0.001 ppm (1 ppb)

Accuracy

Free Chlorine:

- $\pm 3\%$ of the reference test** (DPD) at constant pH less than 7.2 (± 0.2 pH unit)
- $\pm 10\%$ of the reference test** (DPD) at stable pH less than 8.5 (± 0.5 pH unit from the pH at calibration)

Total Chlorine:

- $\pm 10\%$ of the reference test** (DPD) at stable pH less than 8.5 (± 0.5 pH unit from the pH at calibration)
- $\pm 20\%$ of the reference test** (DPD) at stable pH greater than 8.5

Repeatability

30 ppb or 3%, whichever is greater

Response Time

Free Chlorine: 140 seconds or less for 90% change (T90) at a stable temperature and pH

Total Chlorine: 100 seconds or less for 90% change (T90) at a stable temperature and pH

Sampling Time

Continuous

Interferences

Free Chlorine: Monochloramine, chlorine dioxide, ozone, and chalk deposits

Total Chlorine: Chlorine dioxide, ozone, and chalk deposits

Pressure Limit

0.5 bar, no pressure impulses and/or vibrations

Sample Flow Rate

30 to 50 L/hour (7.9 to 13.2 gal/hour),
Optimal is 40 L/hour (10.5 gal/hour)

Sample pH

4-9

Sample Temperature (compensated for fluctuations)

5 to 45°C (41 to 113°F)

Temperature Compensation

Internal temperature sensor

Storage Temperature

Sensor: 0 to 50°C (32 to 122°F) dry, without electrolyte

Electrolyte: 15 to 25°C (59 to 77°F)

Power Requirements

12 Vdc, 30 mA maximum (supplied by controller)

Dimensions (sensor only)

195 mm (7.68 in.)/25 mm (0.98 in.) (length/diameter)

Cable Length

1 m (between gateways and sc-controller)

Cable Connection

5 pin, M12 connector

Measurement Method

Reagentless, electrochemical, three-electrode amperometric system

Calibration Methods

1-point or 2-point (zero and slope) calibration

Material

Corrosion-resistant materials, fully-submersible (stainless steel, PVC, silicon rubber and polycarbonate)

Warranty

1-year warranty on the electrode body, includes the electronics

Panel (including SS Panel, Gateway, Chlorine Sensor Flow Cell, pH Sensor Flow Cell)

Operating Temperature

0 to 45°C (32 to 113°F)

Storage Temperature (panel only)

-20 to 60°C (-4 to 149°F)

Power Requirements

12 Vdc $\pm 10\%$, at 100 mA maximum (supplied by sc controller)

Mounting

Flat, vertical surface

Connections

Sample Line: 1/4-inch OD

Drain Line (pH Flow Cell Outlet): 1/2-inch ID

Panel Dimensions

Length 482.6mm (19 in.) x Width 495.3mm (19.5 in.) x Depth 151.2mm (5.95 in.) (with panel-mounted components)

Weight

Approximately 5.5 kg (12 lbs)
(panel and empty panel-mounted components only)

Controller Platform

sc controller models

Complete Analyzer (Panel + Sensor)

Waterproof Rating

Current rating for Sc100/1000/200 controllers, gateway, and sensors – IP65 (NEMA 4X)

Certification

CE / ETL, EMC

Shipping Weight

Approximately 9.1 kg (20 lbs)

**Reference measurement must be conducted at the analyzer sampling point.

*Specifications subject to change without notice.

Principle of Operation

Amperometry is an electrochemical technique that measures the change in current resulting from chemical reactions taking place on the electrodes. The generated current is proportional to the analyte concentration. A typical amperometric sensor consists of two dissimilar electrodes—an anode and a cathode (i.e. silver/platinum or copper/gold, respectively).

Typically, the electrodes are covered with a membrane cap containing electrolyte, providing for better selectivity of the analysis. Additionally, a small constant electrical voltage is applied across the electrodes.

Below is a general schematic of the reduction-oxidation reaction taking place in a simple 2-electrode amperometric system:

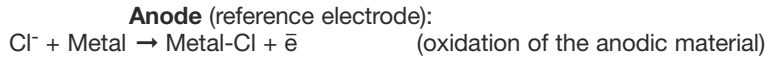

In a three-electrode amperometric system, such as used in the CLF10 sc and CLT10 sc, the anode is essentially split into two parts—a reference and an auxiliary (or counter) electrode. These systems are always supported by special electrical circuit directing the voltage between all electrodes. The three-electrode design generally makes the measurements more stable and provides longer life for the working and reference electrodes.

Engineering Specifications

- The analyzer shall come with a rugged corrosion resistant mounting panel bearing pre-mounted equipment to provide easy installation.
- The instrument shall be a continuous-reading analyzer that utilizes amperometric technology with a three-electrode sensor design.
- The measurement range shall be 0 to 10 ppm of (free or total) chlorine in relation to a standard reference method.
- The response time (T90) shall be 140 seconds or less.
- The low Limit of Detection (LOD) shall be 0.03 ppm or lower.
- The Practical Limit of Quantitation (PLOQ) shall be 90 ppb or lower
- The instrument shall be equipped with a flow-through cell containing a non-contacting flow sensor.
- The instrument shall provide both visual and electronic notification of insufficient sample flow.
- The instrument shall provide chlorine residual measurements within sample pH range of 4 to 9 and temperature range of 5 to 45 degrees Celsius or 41 to 113 degrees Fahrenheit.
- The sensor shall internally compensate for the sample temperature and pH fluctuations.
- The analyzer shall provide monitoring for pH and/or chlorine measurement deviations using Hach Calibration Watch algorithm.
- The analyzer shall provide reagent-free operation without the need for sample conditioning in clean water applications.
- The instrument shall be connected to a controller from the Hach sc controller family.
- The analyzer shall be compatible with the optional Hach cleaning system.
- The instrument shall be the CLF10 sc or CLT10 sc analyzer manufactured by Hach Company.

Dimensions

The analyzer should be installed in an accessible location. It can be mounted on a flat, vertical surface (such as a wall, panel, stand, etc.). It should allow for access for any checking or maintenance. Sample flow should meet the specifications on previous page.

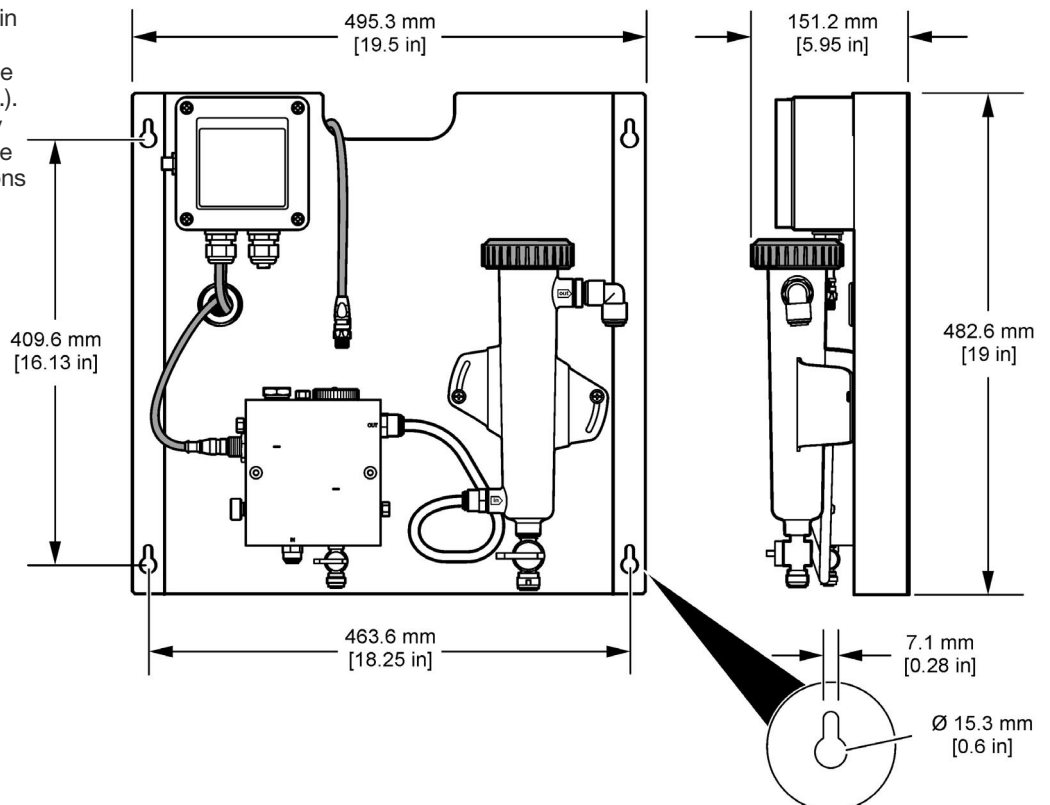

Ordering Information

CLF10 sc Free Chlorine Sensor with sc200 Controller and SS Panel

2980900	CLF10sc, sc200 Single Input, pH
2981000	CLF10sc, sc200 Single Input, Combo pH
2981100	CLF10sc, sc200 Single Input, Grab Sample
2982200	CLF10sc, sc200 Dual Input Combo pH
2982100	CLF10sc, sc200 Dual Input, pH
2982300	CLF10sc, sc200 Dual Input, Grab Sample
2981200	CLF10sc, sc200 Single Input, pH, Metric
2981300	CLF10sc, sc200 Single Input, Combo pH, Metric
2981400	CLF10sc, sc200 Single Input, Grab Sample, Metric
2982400	CLF10sc, sc200 Dual Input, pH, Metric
2982500	CLF10sc, sc200 Dual Input, Combo pH, Metric
2982600	CLF10sc, sc200 Dual Input, Grab Sample, Metric
2987500	CLF10sc, sc200 Single Input, pH, 24 Vdc, Metric
2987600	CLF10sc, sc200 Single Input, Combo pH, 24 Vdc, Metric
2987700	CLF10sc, sc200 Single Input, Grab Sample, 24 Vdc, Metric

CLT10 sc Total Chlorine Sensor with sc200 Controller and SS Panel

2981500	CLT10sc, sc200 Single Input, pH
2981600	CLT10sc, sc200 Single Input, Combo pH
2981700	CLT10sc, sc200 Single Input, Grab Sample
2982700	CLT10sc, sc200 Dual Input, pH
2982800	CLT10sc, sc200 Dual Input, Combo pH
2982900	CLT10sc, sc200 Dual Input, Grab Sample
2981800	CLT10sc, sc200 Single Input, pH, Metric
2981900	CLT10sc, sc200 Single Input, Combo pH, Metric
2982000	CLT10sc, sc200 Single Input, Grab Sample, Metric
2983000	CLT10sc, sc200 Dual Input, pH, Metric
2983100	CLT10sc, sc200 Dual Input, Combo pH, Metric
2983200	CLT10sc, sc200 Dual Input, Grab Sample, Metric
2987400	CLT10sc, sc200 Single Input, pH, 24 Vdc, Metric
2987800	CLT10sc, sc200 Single Input, Combo pH, 24 Vdc, Metric
2987900	CLT10sc, sc200 Single Input, Grab Sample, 24 Vdc, Metric

Note: See LIT #2665 for more information about the combinations possible with the sc200.

CLT10 sc Total Chlorine Analyzer Panel Only

LXV45B.99.13022	w/ pH Differential Sensor
LXV45B.99.12022	w/ pH Combination Sensor
LXV45B.99.11022	Grab Sample Only

Metric sizing available for all configurations.

Accessories

LZY051	Acidification/Cleaning Kit
9159900	Sample Conditioning Kit
9181500	pH Differential Analog pH Sensor, Ryton
9181600	Combination Analog pH Sensor, Ryton

Replacement Parts

9150400	Sensor, Free Chlorine
9150300	Sensor, Total Chlorine
9160200	Membrane Replacement Kit, Free Chlorine Sensor
9180900	Membrane Replacement Kit, Total Chlorine Sensor
9160600	Electrolyte, Free Chlorine Sensor 100 mL
9181400	Electrolyte, Total Chlorine Sensor 100 mL

Lab Products for Method 334.0

5870062	Pocket Colorimeter II System, Chlorine MR/HR
1426810	Chlorine Standard Solution, 10-mL Voluette® Ampule, 50–75 mg/L 16/pkg
2980500	DPD Chlorine-MR Spec [✓] Secondary Standards Kit

For more information on this method, please visit: www.hach.com/method334

Lit. No. 2679 Rev 1

J10 Printed in U.S.A.

©Hach Company, 2010. All rights reserved.

In the interest of improving and updating its equipment, Hach Company reserves the right to alter specifications to equipment at any time.

At Hach, it's about learning from our customers and providing the right answers. It's more than ensuring the quality of water—it's about ensuring the quality of life. When it comes to the things that touch our lives...

Keep it pure.

Make it simple.

Be right.

For current price information, technical support, and ordering assistance, contact the Hach office or distributor serving your area.

In the United States, contact:

HACH COMPANY World Headquarters
P.O. Box 389
Loveland, Colorado 80539-0389
U.S.A.
Telephone: 800-227-4224
Fax: 970-669-2932
E-mail: orders@hach.com
www.hach.com

U.S. exporters and customers in Canada, Latin America, sub-Saharan Africa, Asia, and Australia/New Zealand, contact:

HACH COMPANY World Headquarters
P.O. Box 389
Loveland, Colorado 80539-0389
U.S.A.
Telephone: 970-669-3050
Fax: 970-461-3939
E-mail: intl@hach.com
www.hach.com

In Europe, the Middle East, and Mediterranean Africa, contact:

HACH LANGE GmbH
Willstätterstraße 11
D-40549 Düsseldorf
GERMANY
Tel: +49 (0) 211 5288-0
Fax: +49 (0) 211 5288-143
E-mail: info@hach-lange.de
www.hach-lange.com



Be Right™